



Inter-M, Ltd. (Korea) began operations in 1983.

Since then, Inter-M has grown to become one of the largest manufacturers of professional audio and commercial sound electronics equipment in the world.

Inter-M has gained worldwide recognition for its own branded products, as well as private label manufacturing of electronics sold under other names (OEM).

The company is no longer just a Korean company, but rather a global company that is truly international in scope, with factories and offices in Korea and China, and sales and marketing operations located in Japan, Europe, and the U.S.A.

With more than 850 employees around the globe, Inter-M is well-poised for further growth and expansion.

INTER-M AMERICAS, INC.

1 EAST BEACON LIGHT LANE CHESTER, PA USA 19013-4409
TEL : 1-610-874-8870, FAX : 1-610-874-8890
Home Page : <http://www.inter-m.net>, E-mail : service@inter-m.net

INTER-M Corporation

SEOUL OFFICE: 653-5 BANGHAK-DONG, DOBONG-KU, SEOUL, KOREA
TEL : 82-2-2289-8140~8, FAX : 82-2-2289-8149
Home Page : <http://www.inter-m.com>, E-mail : export@inter-m.com

Operating Manual



PAM-120A/340A/480A Public Address Amplifier

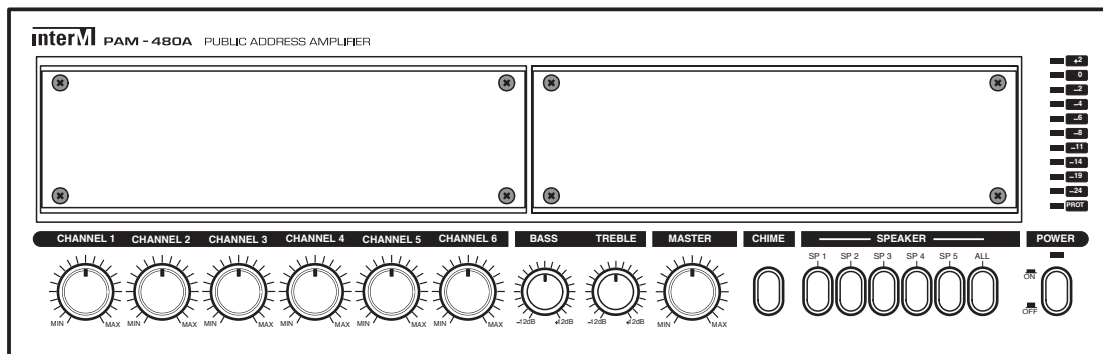

interM

Contents

Welcome	
Warning.....	1
Unpacking.....	2
Installation	
Environment.....	2
Important Safety Instructions.....	2
Features	3
Accessories.....	3
Operation	3
Front Panel	4
Rear Panel	
PAM-120A.....	6
PAM-340A/480A.....	8
Connecting Speakers	11
Applications	
PAM-120A.....	13
PAM-340A/480A.....	14
Block Diagram	
PAM-120A.....	15
PAM-340A/480A.....	16
Specifications	17
Service	
Procedures.....	18
Schematic.....	18
Parts List.....	18
Variations and Options	18
Warranty	18

Welcome

A personal welcome to you from the management and employees of Inter-M

All of the co-workers here at Inter-M are dedicated to providing excellent products with inherently good value, and we are delighted you have purchased one of our products.

We sincerely trust this product will provide years of satisfactory service, but if anything is not to your complete satisfaction, we will endeavor to make things right.

Welcome to Inter-M, and thank you for becoming part of our worldwide extended family!

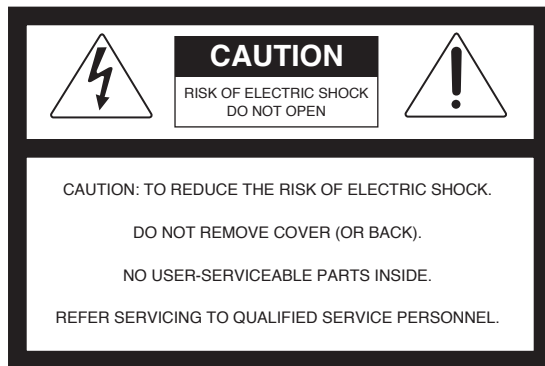

WARNING

To prevent fire or shock hazard, do not expose the unit to rain or moisture.

*Do not install this equipment in a confined space such as a book case or similar unit.

*The apparatus shall not be exposed to dripping or splashing and no objects filled with liquids, such as vases, shall be placed on the apparatus.

*Worded: "WARNING FOR YOUR PROTECTION PLEASE READ THE FOLLOWING-WATER AND MOISTURE: Unit should not be used near water (e.g. near a bathtub, washbowl, kitchen sink, laundry tub, in a wet basement, or near a swimming pool, etc). Care should be taken so that objects do not fall and liquids are not spilled into the enclosure through openings."



This symbol is intended to alert the user to the presence of uninsulated "dangerous voltage" within the product's enclosure that may be of sufficient magnitude to constitute a risk of electric shock to persons.



This symbol is intended to alert the user to the presence of important operation and maintenance (servicing) instructions in the literature accompanying the appliance.

Caution: To prevent electric shock do not use this (polarized) plug with an extension cord, receptacle or other outlet unless the blades can be fully inserted to prevent blade exposure.

Attentions: Pour prévenir les chocs électriques ne pas utiliser cette fiche polarisée avec un prolongateur, une prise de courant ou une autre sortie de courant, sauf si les lames peuvent être insérées à fond sans en laisser aucune partie à découvert.

Unpacking

Although your PAM-120A or PAM-340A or PAM-480A is neither complicated nor difficult to operate, we recommend you take a few minutes to read this brief manual and familiarize yourself with the important information regarding product features, setup and operation.

As with most electronic devices, we strongly recommend you retain the original packaging. In the unlikely event the product must be returned for servicing, the original packaging (or reasonable equivalent) is required.

Installation

Environment

Never place this product in an environment which could alter its performance or reduce its service life. Such environments usually include high levels of heat, dust, moisture, and vibration.

Important Safety Instructions

1. Read these instructions.
2. Keep these instructions.
3. Heed all warnings.
4. Follow all instructions.
5. Do not use this apparatus near water.
6. Clean only with dry cloth.
7. Do not block any ventilation openings. Install in accordance with the manufacturer's instructions.
8. Do not install near any heat sources such as radiators, heat registers, stoves, or other apparatus (including amplifiers) that produce heat.
9. Do not defeat the safety purpose of the polarized or grounding-type plug. A polarized plug has two blades with one wider than the other. A grounding type plug has two blades and a third grounding prong. The wide blade or the third prong are provided for your safety. If the provided plug does not fit into your outlet, consult an electrician for replacement of the obsolete outlet.
10. Protect the power cord from being walked on or pinched particularly at plugs, convenience receptacles, and the point where they exit from the apparatus.
11. Only use attachments/accessories specified by the manufacturer.
12. Use only with the cart, stand, tripod, bracket, or table specified by the manufacturer, or sold with the apparatus. When a cart is used, use caution when moving the cart/apparatus combination to avoid injury from tip-over.
13. Unplug this apparatus during lightning storms or when unused for long periods of time.
14. Refer all servicing to qualified service personnel. Servicing is required when the apparatus has been damaged in any way, such as power-supply cord or plug is damaged, liquid has been spilled or objects have fallen into the apparatus, the apparatus has been exposed to rain or moisture, does not operate normally, or has been dropped.



Features

- MODULAR DESIGN

Optional modules can be installed in multiple configurations for convenience and ease of use. Choose the PAM-CDA (Compact Disc), PAM-T (AM/FM Tuner) or PAM-D (Cassette Deck) modules to expand the PAM-120A/340A/480A's audio capabilities.

- INDIVIDUAL INPUT GAIN CONTROLS

Rear-panel gain controls for each input channel for total control of individual levels.

- SPEAKER SELECT

Six speaker select switches enable you to select any combination of up to five speakers.

- SELECTABLE PRIORITY MUTING

Switchable audio signal priority for Channels 1 and 2, Chime and Telephone input over other input sources.

- REMOTE CONTROL INPUT (only PAM-340A/480A)

Individual speaker zones can be selected and chime can be operated by wired remote control.

- ANNOUNCEMENT CHIME

Convenient four-tone chime for use with announcements.

- EM(EMERGENCY) - OPTIONAL EMERGENCY VOICE IC (only PAM-340A/480A)

When EM switch is pressed in emergencies, EM broadcasting stored in VOICE IC is outputted.

Operation

Make certain that speakers and input sources are properly connected before switching on.

Keep volume levels turned down before switching on.

NOTE: The system's operation is delayed by approximately three seconds after pressing the power switch. This is due to the built-in protection circuitry, designed to protect the speakers and other system components.

Front Panel

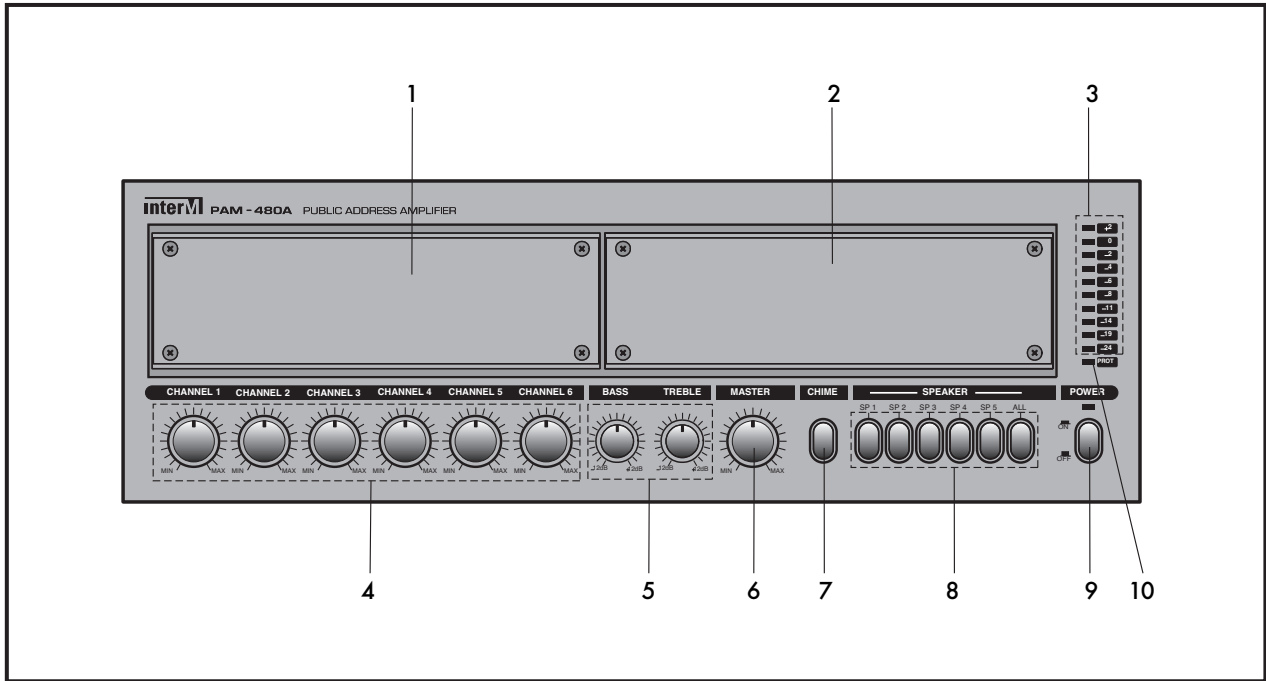

1. TUNER MODULE BAY

This panel provides for installation of optional PAM-T (AM/FM Tuner) Module, via the unit's internal connectors.

2. CASSETTE DECK AND CD MODULE BAY

This panel provides for installation of optional PAM-CDA (CD Player) or PAM-D (Cassette Deck) Modules, via the unit's internal connectors.

3. OUTPUT LEVEL DISPLAY

This seven-segment LED meter indicates the amplifier's output level in RMS.

4. CHANNEL 1-6 VOLUME

Controls the individual volume levels of Channels 1-6.

5. TONE CONTROL

Individual Bass and Treble controls are used to cut (decrease) or boost (increase) the lower and higher frequencies ± 12 dB.

6. MASTER VOLUME

This rotary switch controls the overall output volume of the amplifier's output signal.

7. CHIME BUTTON

Pressing this switch activates the chime circuitry.

8. SPEAKER SELECTOR SWITCHES

These switches are used to select output to any combination of up to five individual speakers.

9. POWER SWITCH

Pressing this switch turns the unit on, as indicated by the Power LED above the switch. Pressing it again turns the unit off.

10. PROTECTION INDICATOR

This LED indicates the state of the amplifier's protection circuitry. When the Protection LED is on (illuminated), the protection circuitry is active, indicating that the unit is not operating normally. This is typically due to overheating or power limiting. Please check the Input and Output condition of the amplifier.

Rear Panel (PAM-120A)

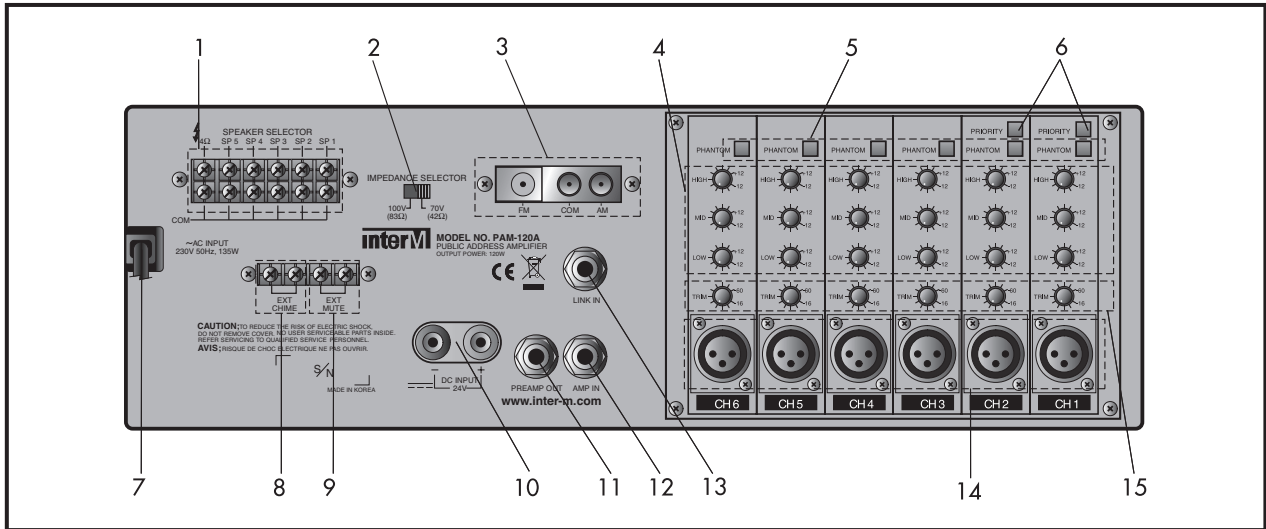

1. SPEAKER OUTPUT TERMINAL STRIP

Connect up to five individual speakers to this strip.

Impedances for 4Ω, 70V and 100V operation are shown below. Connect speakers whose combined impedance is equal to or higher than the rated output impedance, as shown below.

2. IMPEDANCE SELECTOR

Selects between high impedance operation at 70V or 100V distributed systems. Note that when speakers are connected to the 4Ω terminal, this switch is inactive.

MODEL	4Ω	70V	100V
PAM-120A	22V	42Ω	83Ω

3. ANTENNA CONNECTOR (OPTIONAL)

This terminal is used to connect the antenna, when used with the optional PAM-T AM/FM Tuner module.

4. EQ CONTROLS

Three-band equalization control provides ±12dB of cut (decrease) or boost (increase) over the high, mid and low frequency ranges of the individual channel signals.

HIGH – 10kHz, ±12dB

MID – 1kHz, ±12dB

LOW – 100Hz, ±12dB

5. PHANTOM POWER SWITCH

This switch turns the phantom power supply on or off for all channels. When the switch is turned on, +22V DC power is supplied to pins 2 and 3 of each channel's input connector.

Use phantom power when connecting condenser microphones, which require an external power supply.

NOTE: It is safe to connect most modern dynamic microphones or line level devices to the channel inputs when phantom power is activated. However, some older ribbon microphones may be damaged by phantom power, and certain unbalanced line level devices may malfunction or produce an audible hum when phantom power is active.

6. PRIORITY SWITCH

When selected, these switches will give priority to Channels 1 and/or 2 over all other channels and audio inputs.

7. AC POWER INPUT

Connect a standard three-pin AC cable your AC outlet.

8. EXT CHIME

When these two terminals are shorted, the four-tone chime circuitry is activated.

9. EXT MUTE

When these two terminals are shorted by wired remote, signals from Input Channels 3-6 and any optional modules are muted. Signals from Channel 1, Channel 2, Link In and Chime are not muted.

10. DC INPUT TERMINALS

These terminals are provided for the connection of backup battery. Connect a 24VDC battery source to these terminals. Make certain the red terminal is connected to the battery's positive (+) side, and the black terminal to the battery's negative (-) side.

11. PREAMP OUTPUT

This output connects the unit with an external power amplifier. Inserting a plug into the Preamp Out jack will disconnect signal to the unit's power amp, sending the output of the internal mixer to the external amplifier.

12. AMP IN

This input connects an external mixer or preamp with the unit's power amp. Inserting a plug into the Amp In jack will disconnect all input signal from the unit's internal mixer. Only signal from the external source will be heard.

13. LINK IN

This line-level input connects the unit with an external mixer for expanded input channels.

14. CHANNEL INPUTS 1-6

These balanced three-pin XLR connectors accept a standard microphone cable or other low impedance signal. Optional phone jack, screw terminal, RCA jack or transformer balanced inputs are also available.

15. INPUT GAIN CONTROLS

These knobs provide continuous control of the input levels for each of the six input channels. When adjusting the input gain, make certain that the levels are not set too high, or distortion will result.

The approximate levels for these controls are as follows:

MIC	mic level	(-50dB ~ -60dB)
MIC ATT	instrument level	(-30dB ~ -50dB)
AUX	line level	(-20dB ~ -30dB)

Rear Panel (PAM-340A/480A)

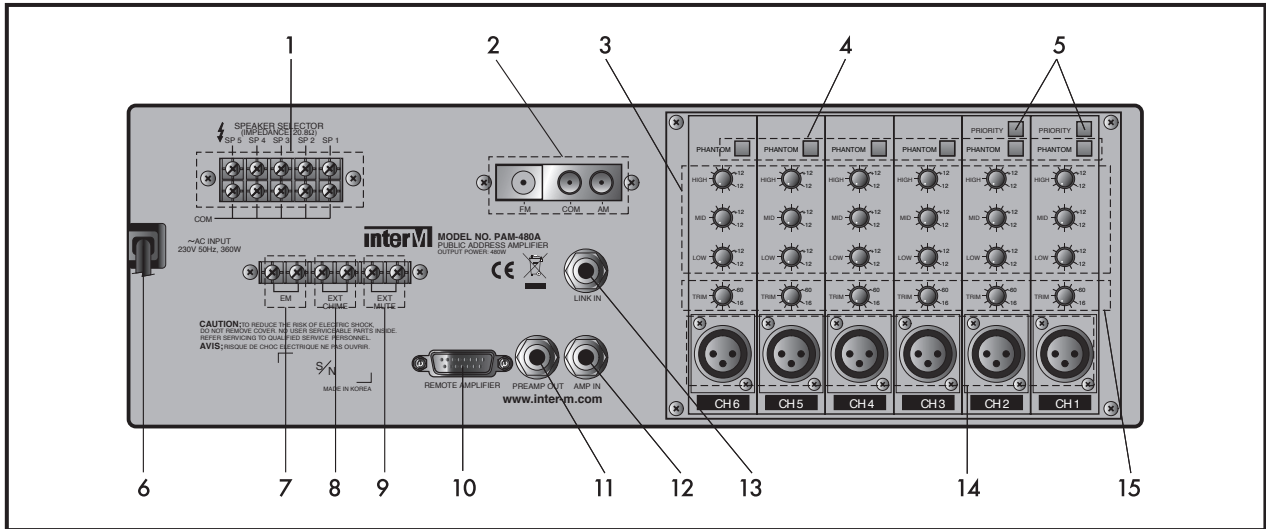

1. SPEAKER OUTPUT TERMINAL STRIP

Connect up to five individual speakers to this strip.

Impedances for 100V operation are shown below. Connect speakers whose combined impedance is equal to or higher than the rated output impedance, as shown below.

MODEL	100V
PAM-340A	29.4Ω
PAM-480A	20.8Ω

2. ANTENNA CONNECTOR (OPTIONAL)

This terminal is used to connect the antenna, when used with the optional PAM-T AM/FM Tuner module.

3. EQ CONTROLS

Three-band equalization control provides ± 12 dB of cut (decrease) or boost (increase) over the high, mid and low frequency ranges of the individual channel signals.

HIGH – 10kHz, ± 12 dB

MID – 1kHz, ± 12 dB

LOW – 100Hz, ± 12 dB

4. PHANTOM POWER SWITCH

This switch turns the phantom power supply on or off for all channels. When the switch is turned on, +22V DC power is supplied to pins 2 and 3 of each channel's input connector.

Use phantom power when connecting condenser microphones, which require an external power supply.

NOTE: It is safe to connect most modern dynamic microphones or line level devices to the channel inputs when phantom power is activated. However, some older ribbon microphones may be damaged by phantom power, and certain unbalanced line level devices may malfunction or produce an audible hum when phantom power is active.

5. PRIORITY SWITCH

When selected, these switches will give priority to Channels 1 and/or 2 over all other channels and audio inputs.

6. AC POWER INPUT

Connect a standard three-pin AC cable to your AC outlet.

7. EM

When EM switch is connected and pressed in fire or other emergencies, EM broadcasting stored in VOICE IC is outputted.

* Remove an input jack from AMP IN not to affect Emergency signal to be played or adjust the main audio signal to adequate level for emergency broadcasting.

8. EXT CHIME

When these two terminals are shorted by wired remote (see item 14 above), the four-tone chime circuitry is activated.

9. EXT MUTE

When these two terminals are shorted by wired remote (see item 14 above), signals from Input Channels 3-6 and any optional modules are muted. Signals from Channel 1, Channel 2, Link In and Chime are not muted.

10. REMOTE CONTROL INPUT

By connecting a 15-pin D-SUB connector, it is possible to control speaker zone selection and activate the chime via wired remote. Connection terminals for the remote are shown below.

Pin 1: Remote amplifier input signal hot(+)	Pin 8: Remote control 5(Speaker 5)
Pin 2: Remote amplifier input signal cold(-)	Pin 9: Remote control ground
Pin 3: Signal ground	Pin 10: DC +24V
Pin 4: Remote control 1(Speaker 1)	Pin 11: Input Chime
Pin 5: Remote control 2(Speaker 2)	Pin 12: NC
Pin 6: Remote control 3(Speaker 3)	Pin 13: NC
Pin 7: Remote control 4(Speaker 4)	Pin 14, 15: NC

NOTE: Remote controller is used to RM-01.

11. PREAMP OUTPUT

This output connects the unit with an external power amplifier. Inserting a plug into the Preamp Out jack will disconnect signal to the unit's power amp, sending the output of the internal mixer to the external amplifier.

12. AMP IN

This input connects an external mixer or preamp with the unit's power amp. Inserting a plug into the Amp In jack will disconnect all input signal from the unit's internal mixer. Only signal from the external source will be heard.

13. LINK IN

This line-level input connects the unit with an external mixer for expanded input channels.

14. CHANNEL INPUTS 1-6

These balanced three-pin XLR connectors accept a standard microphone cable or other low impedance signal. Optional transformer balanced inputs are also available.

15. INPUT GAIN CONTROLS

These knobs provide continuous control of the input levels for each of the six input channels. When adjusting the input gain, make certain that the levels are not set too high, or distortion will result.

The approximate levels for these controls are as follows:

MIC	mic level	(-50dB ~ -60dB)
MIC ATT	instrument level	(-30dB ~ -50dB)
AUX	line level	(-20dB ~ -30dB)

Connecting Speakers

Before connecting speakers, disconnect the AC power cable. Note the proper connecting terminals as shown below. Make certain that the total impedance is not less than the rated impedance indicated.

- CONNECTING 4Ω OR 8Ω SPEAKER SYSTEMS (only PAM-120A)

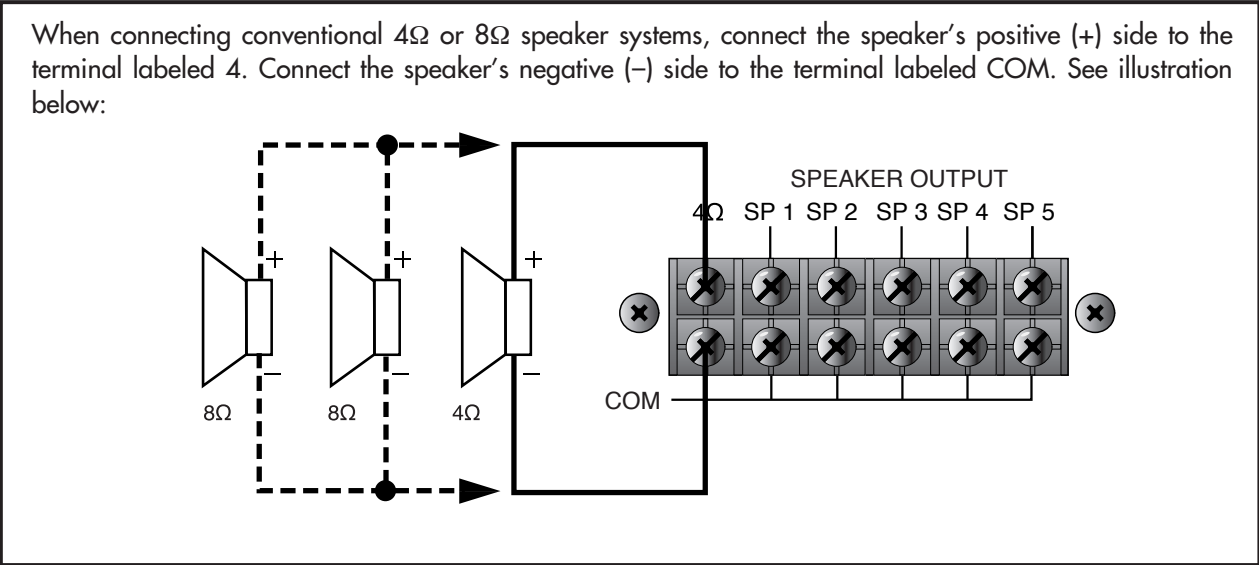

- CONNECTING HIGH-VOLTAGE DISTRIBUTED SPEAKER SYSTEMS

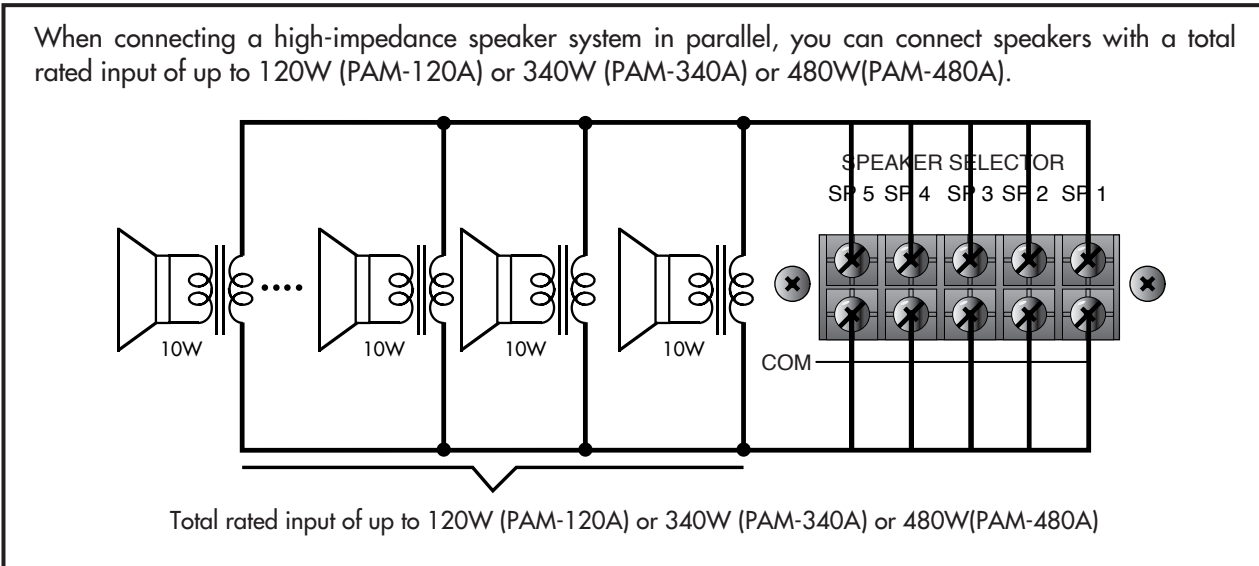

For example, if you are connecting speakers with a rated input of 15W, you can connect up to 8 speakers in parallel, as shown below:

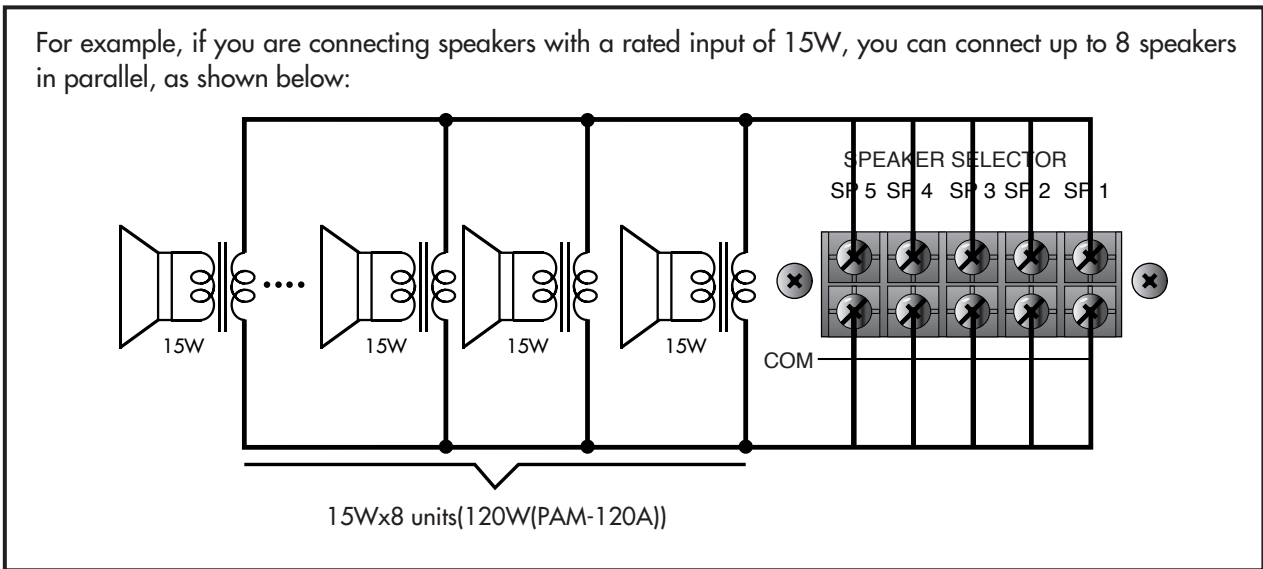

WARNING: Extreme care must be exercised when connecting low-impedance systems, as potentially hazardous voltages may be present at these terminals.

Do not install this equipment in a confined space with less-than-adequate ventilation.

Applications (PAM-120A)

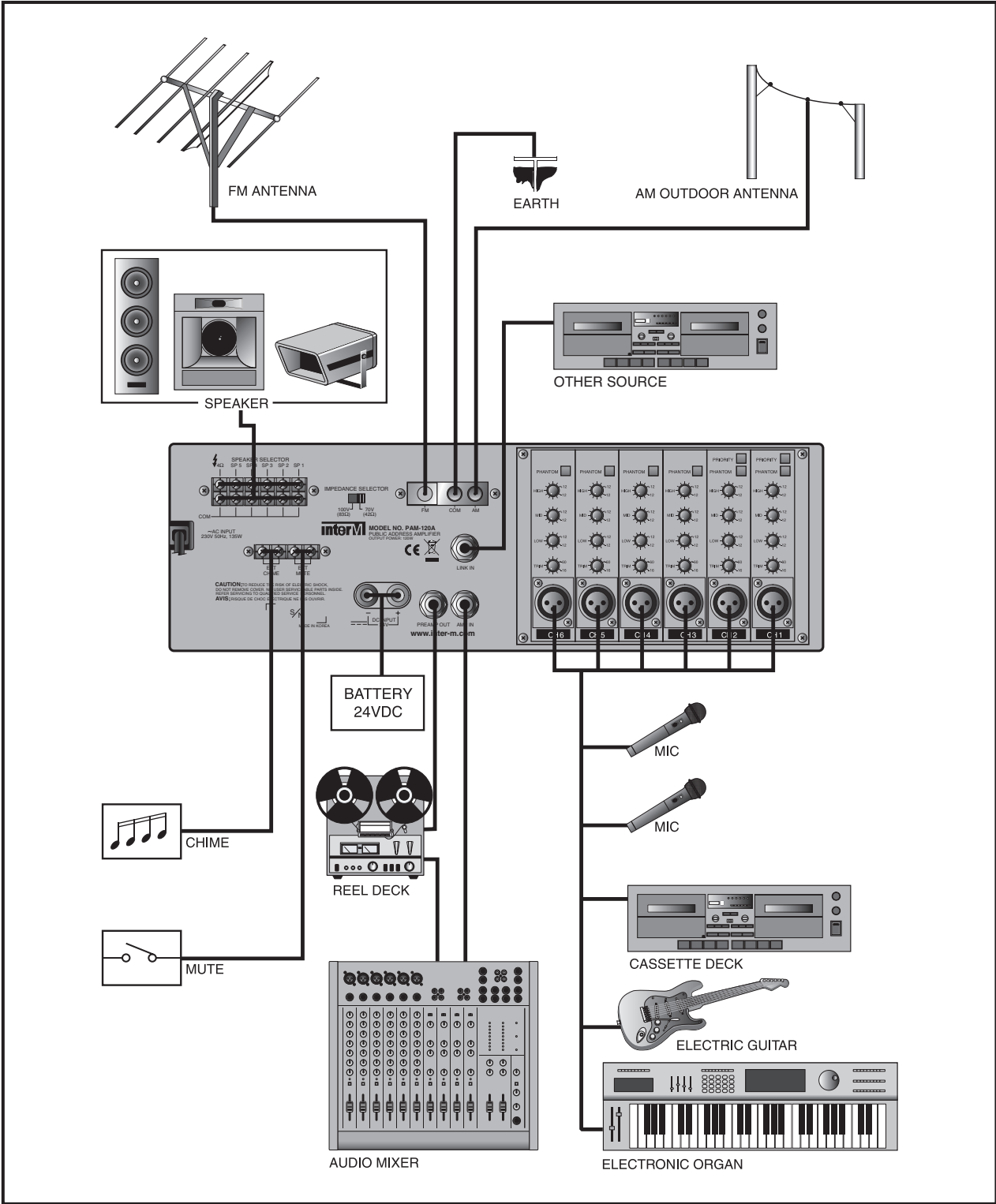

Applications (PAM-340A/480A)

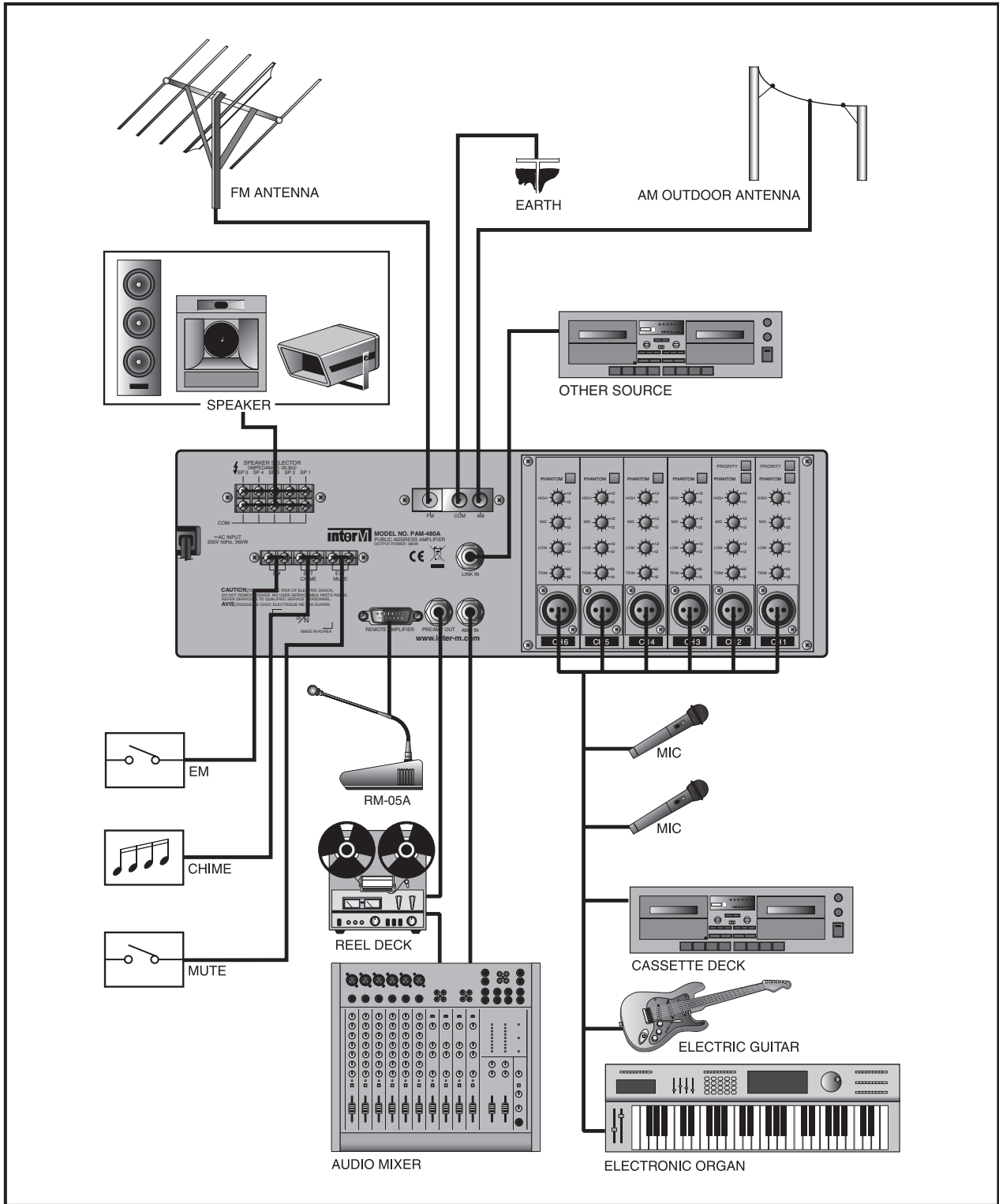

Block Diagram (PAM-120A)

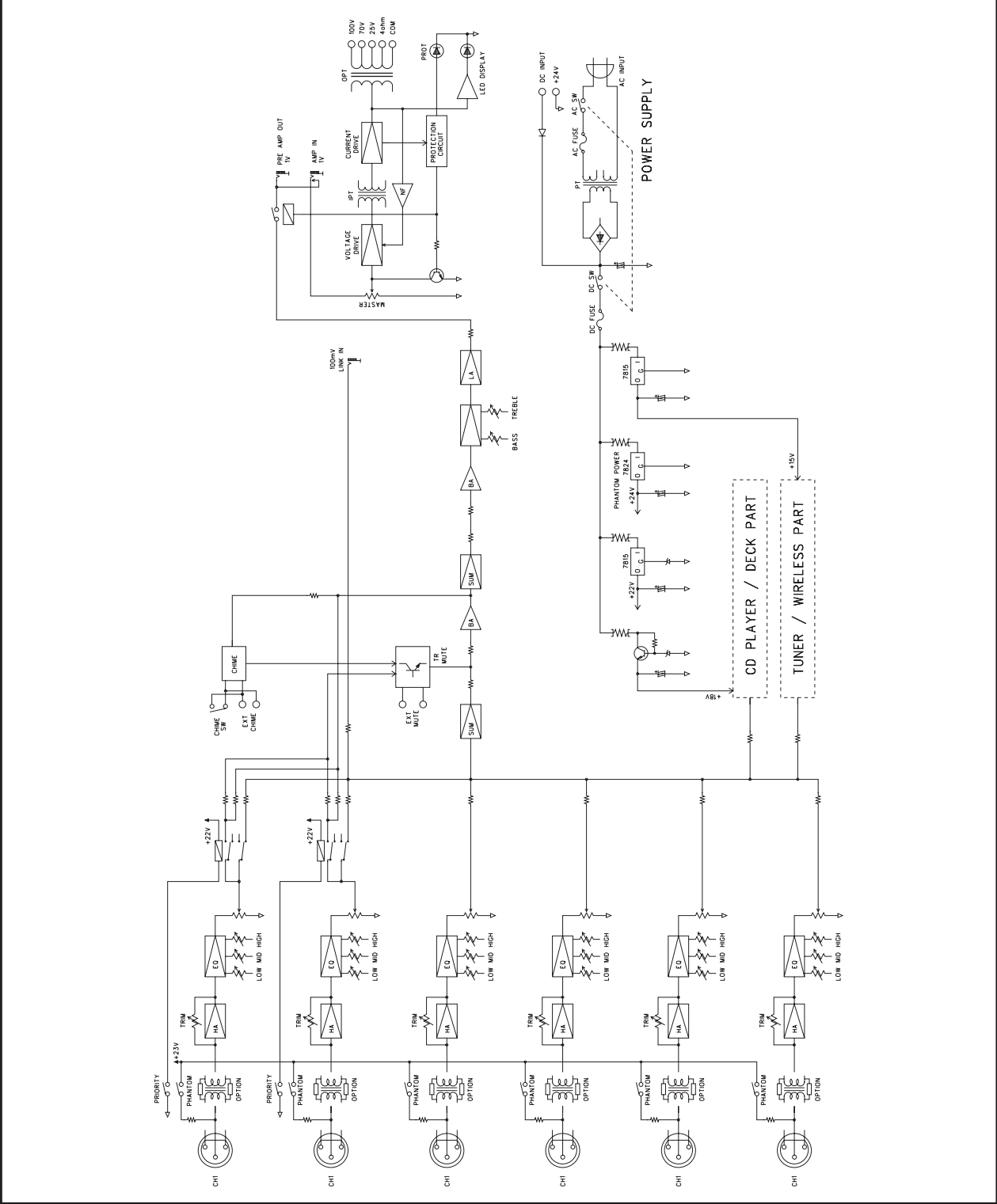

Block Diagram (PAM-340A/480A)

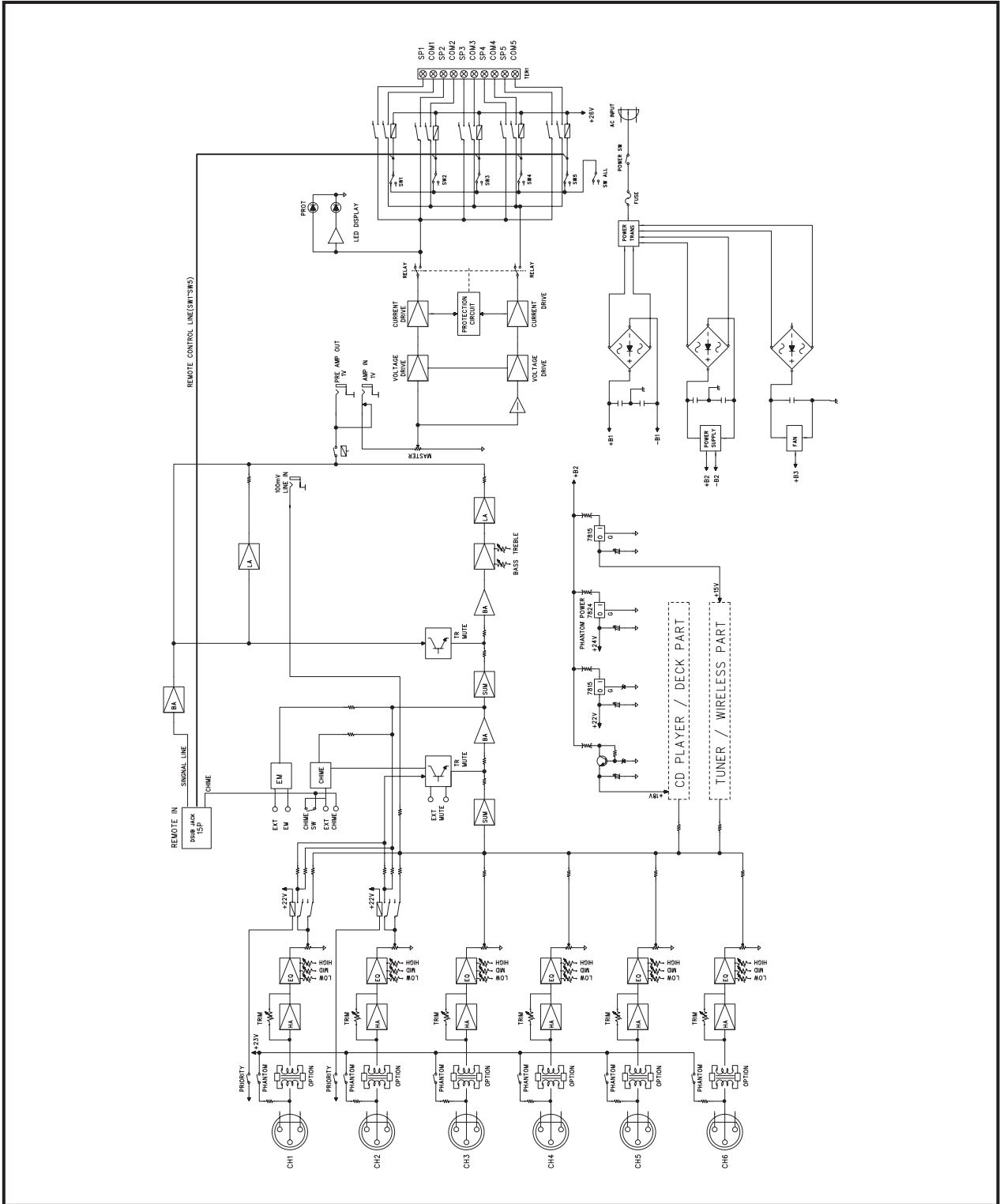

Specifications

Rated Output Power	PAM-120A(THD 1%) : 120W (RMS) PAM-340A(THD 3%) : 340W (RMS) PAM-480A(THD 3%) : 480W (RMS)
Frequency Response	
Amp In	80Hz~20kHz
Link In	80Hz~15kHz
CH1~CH6	120Hz~8kHz
Remote In	120Hz~8kHz(PAM-340A, PAM-480A)
T.H.D.(at 1kHz Rated Output).....	Less than 1%(PAM-120A)
T.H.D.(at 1kHz Half Power Output)	Less than 0.5%(PAM-340A, PAM-480A)
S/N	
Amp In	Better than 90dB(PAM-120A) Better than 88dB(PAM-340A/480A)
Link In	Better than 65dB
CH1~CH6	Better than 50dB
Remote In	Better than 50dB(PAM-340A/480A)
Input Sensitivity/Impedance	
CH1~CH6	
TRIM VR -60dB Position	1mV/10k Ω
TRIM VR -16dB Position	158mV/10k Ω
Link In	100mV/10k Ω
Amp In	1V/47k Ω (PAM-120A) 1V/20k Ω (PAM-340A/480A)
Remote In.....	1V/10K Ω (PAM-340A/480A)
Speaker Output/Impedance.....	PAM-120A : 120W/4 Ω , 70V/42 Ω , 100V/83 Ω PAM-340A : 340W, 100V/29.4 Ω PAM-480A : 480W, 100V/20.8 Ω
Preamp Output/Impedance	1V/600 Ω
Tone Control (100Hz, 10kHz).....	\pm 12dB
CH1~CH6 EQ Control (100Hz, 1kHz, 10kHz)	\pm 12dB
- GENERAL	
Power Source.....	100~120VAC or 220V~240VAC; 50/60Hz, 24V DC(only PAM-120A) (Supplied AC mains transformer depends on country requirements)
Power Consumption	PAM-120A : 135W(1/8 POWER), 200W(1/3 POWER), 300W(FULL POWER) PAM-340A : 260W(1/8 POWER), 400W(1/3 POWER), 620W(FULL POWER) PAM-480A : 360W(1/8 POWER), 550W(1/3 POWER), 880W(FULL POWER)
Weight	PAM-120A : 13kg/28.7lb PAM-340A : 13.5kg/29.7lb PAM-480A : 15.5kg/34.2lb
Dimensions	420(W) x 132(H) x 360(D)mm/16.5(W) x 5.2(H) x 14.2(D)in
Operation Temperature.....	14F~104F (-10°C~+40°C)

* Specifications and design subject to change without notice.

Service

Procedures

Ensure the problem is not related to operator error, or system devices that are external to this unit. Information provided in the troubleshooting portion of this manual may help with this process. Once it is certain that the problem is related to the product contact your warranty provider as described in the warranty section of this manual.

Schematic

A Schematic is available by contacting your warranty provider.

Parts List

A Parts List is available by contacting your warranty provider.

Variations and Options

Variations

Products supplied through legitimate sources are compatible with local AC power requirements.

Options

No optional items are available for this product.

Warranty

Warranty terms and conditions vary by country and may not be the same for all products. Terms and conditions of warranty for a given product may be determined first by locating the appropriate country which the product was purchased in, then by locating the product type.

To obtain specific warranty information and available service locations contact Inter-M directly (in Korea or the USA) or the authorized Inter-M Distributor for your specific country or region.

NOTE
