

NS-B210

NS-C210

Speaker
Enceinte

OWNER'S MANUAL
MODE D'EMPLOI
BEDIENUNGSANLEITUNG
MANUAL DE INSTRUCCIONES
ИНСТРУКЦИЯ ПО ЭКСПЛУАТАЦИИ
使用说明书

Thank you for selecting this YAMAHA product.

PRECAUTIONS

Read this before using the speaker.

- To assure the finest performance, please read this manual carefully. Keep it in a safe place for future reference.
- Install the speaker in a cool, dry, clean place - away from windows, heat sources, sources of excessive vibration, dust, moisture and cold. Avoid sources of electrical noise (transformers, motors). To prevent fire or electrical shock, do not expose this unit to rain or water.
- To prevent the enclosure from warping or discoloring, do not place the speaker where it will be exposed to direct sunlight or excessive humidity.
- Do not place the following objects on the speaker:
Glass, china, small metallic etc.
If glass, etc., falls as a result of vibration and breaks, it may cause personal injury.
A burning candle, etc.
If the candle falls as a result of vibrations, it may cause fire and personal injury.
A vessel with water in it
If the vessel falls as a result of vibrations and water spills, it may cause damage to the speaker, and/or you may get an electric shock.
- Do not place the speaker where foreign material such as dripping water. It might cause fire, damage to this unit, and/or personal injury.
- Do not place the speaker where it is liable to be knocked over or struck by falling objects. Stable placement will also ensure better sound performance.
- Placing the speaker on the same shelf or rack as the turntable can result in acoustical feedback.
- Never put a hand or a foreign object into the port located on the rear of the speaker, as this might cause personal injury and/or damage to the speaker.
- When moving the speaker, do not hold the port, as it might cause personal injury and/or damage to the speaker.
- Any time you notice distortion, reduce the volume control on your amplifier. Never allow your amplifier to be driven into "clipping." Otherwise the speaker may be damaged.
- When using an amplifier with a rated output power higher than the nominal input power of the speaker, care should be taken never to exceed the speaker's maximum input.
- Do not attempt to clean the speaker with chemical solvents, as this might damage the finish. Use a clean, dry cloth.
- Do not attempt to modify or repair the speaker. Contact qualified YAMAHA service personnel when any service is needed. The cabinet should never be opened for any reasons.
- **Secure placement and installation is the owner's responsibility. YAMAHA shall not be liable for any accident caused by improper placement or installation of speakers.**

Information for Users on Collection and Disposal of Old Equipment



This symbol on the products, packaging, and/or accompanying documents means that used electrical and electronic products should not be mixed with general household waste.

For proper treatment, recovery and recycling of old products, please take them to applicable collection points, in accordance with your national legislation and the Directives 2002/96/EC.

By disposing of these products correctly, you will help to save valuable resources and prevent any potential negative effects on human health and the environment which could otherwise arise from inappropriate waste handling.

For more information about collection and recycling of old products, please contact your local municipality, your waste disposal service or the point of sale where you purchased the items.

[Information on Disposal in other Countries outside the European Union]

This symbol is only valid in the European Union. If you wish to discard these items, please contact your local authorities or dealer and ask for the correct method of disposal.

SUPPLIED ACCESSORIES

NS-B210

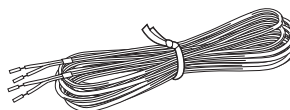

Speaker cable (10m x 1)

NS-C210



Speaker cable (4m x 1)

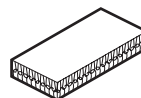

Fastener x 2

PLACING THE SPEAKERS

For NS-B210

Using as 2ch stereo speakers

Better stereo images will be obtained when the speakers are slightly angled in towards the listeners.

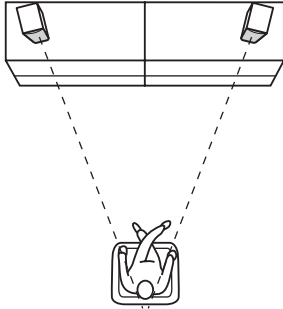

Using as front speakers and surround speakers in a surround system

Position the speakers on both sides of the TV. The positioning of speakers is important, since this dictates the overall sound quality of the surround system. Set up the speakers on the basis of your listening position by following the owner's manual supplied with your amplifier.

And mount the speakers on a wall or place the speakers on a shelf. Determine the best position by following the owner's manual supplied with your amplifier.

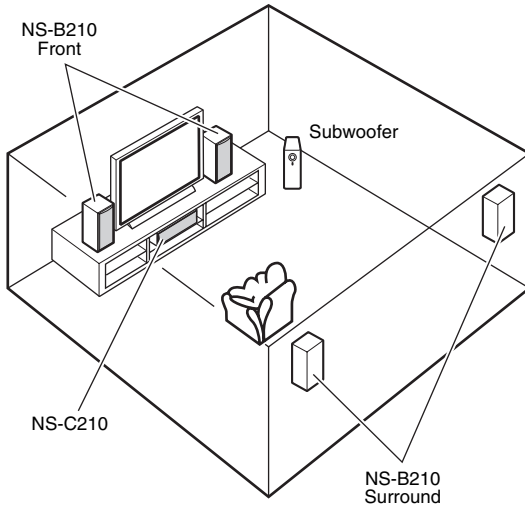

To mount the speakers on a wall by using the attached mounting bracket

Fasten screws into a firm wall or wall support as shown in the figure, and hang the holes of the mounting bracket on the protruding screws.

* Make sure that the screws are secured in the narrow sections of the holes.

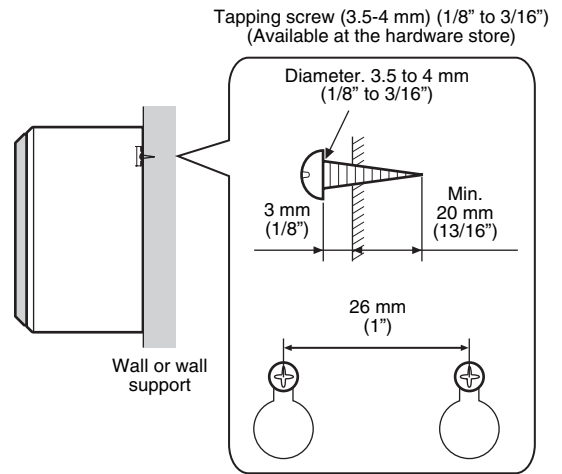

You can also use the screw holes on the bottom of the speaker for installing the speaker using a commercially available speaker bracket (if you do not use the attached mounting bracket).

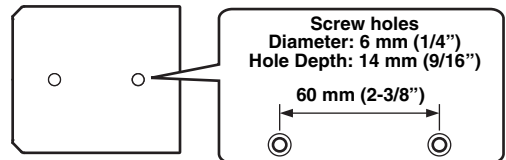

Note

Placing this unit too close to a CRT TV set might impair picture color or create a buzzing noise. Should this happen, move the speaker away (more than 20 cm (7-7/8\")) from the TV set.

When using a PDP or LCD TV, it would not happen.

WARNING

- NS-B210 weighs 1.6 kg (3 lbs. 8 oz.). Do not mount it on thin plywood or a wall with soft surface material. If mounted, the screws may come out and the speaker may fall. This may damage the speaker, or cause personal injury.
- Do not install the speaker on a wall with nails, adhesives, or any other unstable hardware. Long term use and vibrations may cause it to fall.
- To avoid accidents resulting from tripping over loose speaker cables, fix them securely to the floor or wall.

For NS-C210

■ Using as center speaker

Place the speaker on a TV rack or other stable surface. To prevent the speaker from falling down, attach the fasteners provided in each corner of the speaker's underside.

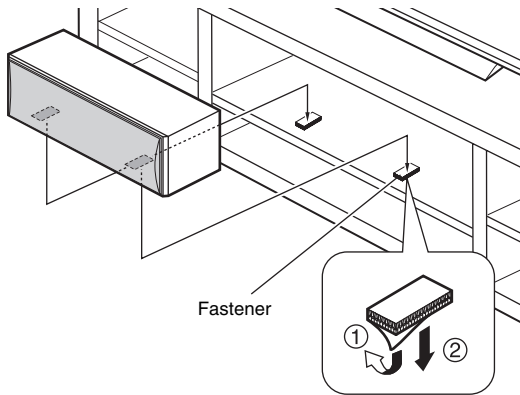

■ To mount the speakers on a wall by using the attached mounting bracket

Fasten screws into a firm wall or wall support as shown in the figure, and hang the holes of the mounting bracket on the protruding screws.

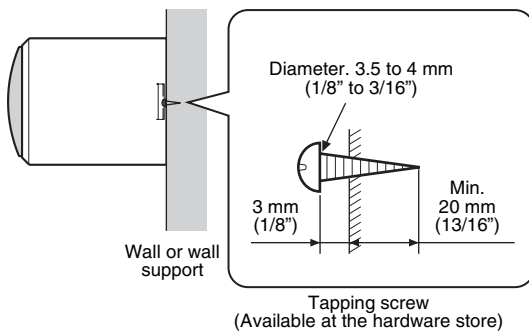
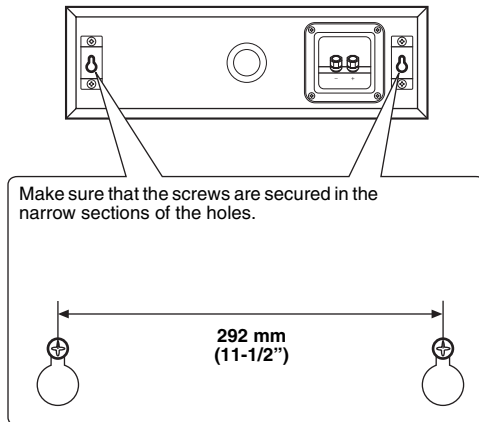

Note

Placing this unit too close to a CRT TV set might impair picture color or create a buzzing noise. Should this happen, move the speaker away (more than 20 cm (7-7/8")) from the TV set.

When using a PDP or LCD TV, it would not happen.

WARNING

- NS-C210 weighs 2 kg (4 lbs. 7 oz.). Do not mount it on thin plywood or a wall with soft surface material. If mounted, the screws may come out and the speaker may fall. This may damage the speaker, or cause personal injury.
- Do not touch the adhesive surface after peeling off the seal as this will weaken its adhesive strength.
- Thoroughly wipe clean the surface where the fasteners are to be attached. Note that adhesive strength is weakened if the surface is dirty, oily or wet, and that this may cause the center speaker to drop.
- Do not install the speaker on a wall with nails, adhesives, or any other unstable hardware. Long term use and vibrations may cause it to fall.
- To avoid accidents resulting from tripping over loose speaker cables, fix them securely to the floor or wall.

CONNECTIONS TO YOUR AMPLIFIER

Before making connections, make sure that the amplifier is switched off.

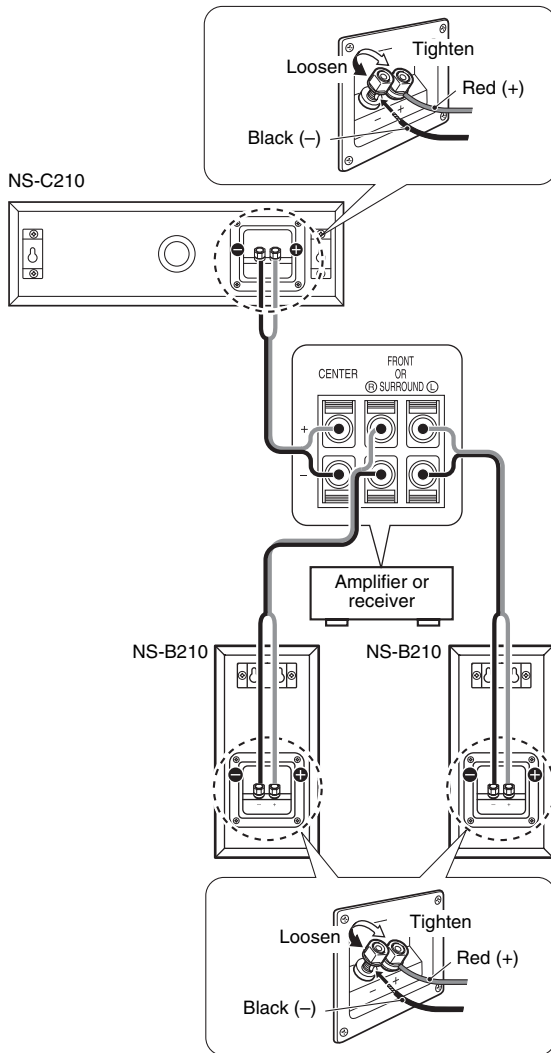

- Connect the screw-type input terminals at the rear of the speakers to the speaker output terminals of the amplifier (or receiver) with the speaker cable.
- Connect the (+) terminals on the amplifier (or receiver) to the (+) terminal of each speaker, making sure to confirm the color-coded wire of the cable at each end. Use the other wire of the cable to connect the (-) terminals of the components.
- Connect one speaker to the left (marked L) terminals of your amplifier, and another speaker to the right (marked R) terminals, making sure not to reverse the polarity (+, -). If one speaker is connected with reversed polarity the sound will be unnatural and lack bass.

How to connect

- 1 Loosen the knob.
- 2 Remove 10 mm (3/8") of insulation from each end of the cables, and twist the exposed conductors together neatly and tightly, as shown below.

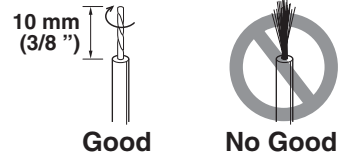

- 3 Insert the bare wire.
- 4 Tighten the knob and secure the cables. Test the firmness of the connection by pulling lightly on the cables at the terminal.

Notes

- Do not let the bare speaker wires touch each other as this could damage the speaker or the amplifier, or both.
- Do not insert the insulation into the hole. Sound may not be produced.

When using a banana plug

Note

Do not take off this cover unless using a banana plug.

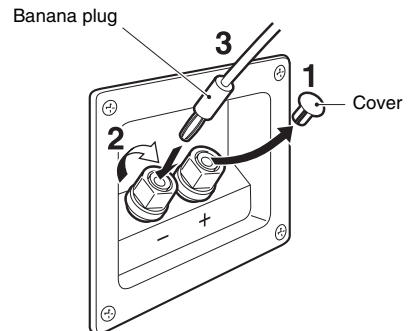

- 1 Remove the cover by pulling it toward you.
- 2 Tighten the terminal knob.
- 3 Simply insert the banana plug into the terminal.

SPECIFICATIONS

NS-B210

Type full-range acoustic suspension speaker system
Non-Magnetic shielding type
Driver 8 cm (3-1/8") full-range × 2
Impedance 6 Ω
Frequency Response 75 Hz to 35 kHz (-10 dB)
to 50 kHz (-30 dB)
Nominal Input Power 40 W
Maximum Input Power 120 W
Sensitivity 86 dB/2.83 V/m
Dimensions (W × H × D) 105 × 215 × 132 mm
(4-1/8" × 8-7/16" × 5-3/16")
Weight 1.6 kg (3 lbs. 8 oz.)

NS-C210

Type 2-way bass reflex speaker system
Non-Magnetic shielding type
Driver 8 cm (3-1/8") cone woofer × 2
2.2 cm (1") balanced dome tweeter
Impedance 6 Ω
Frequency Response 65 Hz to 45 kHz (-10 dB)
to 100 kHz (-30 dB)
Nominal Input Power 40 W
Maximum Input Power 120 W
Sensitivity 86 dB/2.83 V/m
Crossover Frequency 8 kHz
Dimensions (W × H × D) 340 × 105 × 132 mm
(13-3/8" × 4-1/8" × 5-3/16")
Weight 2 kg (4 lbs. 7 oz.)

- Specifications subject to change without notice due to product improvements.
- Care should be taken not to exceed the input power values noted above.

Taking care of the speaker

When you wipe this unit, do not use chemical solvents (e.g., alcohol or thinners, etc.): this might damage the finish. Use a clean, dry cloth. For difficult soils, dampen a soft cloth in water, wring it out, and then wipe with the cloth.

(For polish-finished model) Bumping the surface of the instrument with metal, porcelain, or other hard objects can cause the finish to crack or peel. Use caution.

Limited Guarantee for European Economic Area (EEA) and Switzerland

Thank you for having chosen a Yamaha product. In the unlikely event that your Yamaha product needs guarantee service, please contact the dealer from whom it was purchased. If you experience any difficulty, please contact Yamaha representative office in your country. You can find full details on our website (<http://www.yamaha-hifi.com/> or <http://www.yamaha-uk.com/> for U.K. resident).

The product is guaranteed to be free from defects in workmanship or materials for a period of two years from the date of the original purchase. Yamaha undertakes, subject to the conditions listed below, to have the faulty product or any part(s) repaired, or replaced at Yamaha's discretion, without any charge for parts or labour. Yamaha reserves the right to replace a product with that of a similar kind and/or value and condition, where a model has been discontinued or is considered uneconomic to repair.

Conditions

1. The original invoice or sales receipt (showing date of purchase, product code and dealer's name) MUST accompany the defective product, along with a statement detailing the fault. In the absence of this clear proof of purchase, Yamaha reserves the right to refuse to provide free of charge service and the product may be returned at the customer's expense.
2. The product MUST have been purchased from an AUTHORISED Yamaha dealer within the European Economic Area (EEA) or Switzerland.
3. The product must not have been the subject of any modifications or alterations, unless authorised in writing by Yamaha.
4. The following are excluded from this guarantee:
 - a. Periodic maintenance and repair or replacement of parts due to normal wear and tear.
 - b. Damage resulting from:
 - (1) Repairs performed by the customer himself or by an unauthorised third party.
 - (2) Inadequate packaging or mishandling, when the product is in transit from the customer. Please note that it is the customer's responsibility to ensure the product is adequately packaged when returning the product for repair.
 - (3) Misuse, including but not limited to (a) failure to use the product for its normal purpose or in accordance with Yamaha's instructions on the proper use, maintenance and storage, and (b) installation or use of the product in a manner inconsistent with the technical or safety standards in force in the country where it is used.
 - (4) Accidents, lightning, water, fire, improper ventilation, battery leakage or any cause beyond Yamaha's control.
 - (5) Defects of the system into which this product is incorporated and/or incompatibility with third party products.
 - (6) Use of a product imported into the EEA and/or Switzerland, not by Yamaha, where that product does not conform to the technical or safety standards of the country of use and/or to the standard specification of a product sold by Yamaha in the EEA and/or Switzerland.
 - (7) Non AV (Audio Visual) related products.
(Products subject to "Yamaha AV Guarantee Statement" are defined in our website at <http://www.yamaha-hifi.com/> or <http://www.yamaha-uk.com/> for U.K. resident.)
5. Where the guarantee differs between the country of purchase and the country of use of the product, the guarantee of the country of use shall apply.
6. Yamaha may not be held responsible for any losses or damages, whether direct, consequential or otherwise, save for the repair or replacement of the product.
7. Please backup any custom settings or data, as Yamaha may not be held responsible for any alteration or loss to such settings or data.
8. This guarantee does not affect the consumer's statutory rights under applicable national laws in force or the consumer's rights against the dealer arising from their sales/purchase contract.

规格

NS-B210

类型	全频声学悬挂式扬声器系统 非磁屏蔽型
驱动单元	8 cm 全频 × 2
阻抗	6 Ω
频率响应	75 Hz 至 35 kHz (-10 dB) 至 50 kHz (-30 dB)
标称输入功率	40 W
最大输入功率	120 W
灵敏度	86 dB/2.83 V/m
尺寸 (宽×高×深)	105 × 215 × 132 mm
重量	1.6 kg

NS-C210

类型	2 路低音反射扬声器系统 非磁屏蔽型
驱动单元	8 cm 锥形低音扬声器 × 2 2.2 cm 平衡球顶形高频扬声器
阻抗	6 Ω
频率响应	65 Hz 至 45 kHz (-10 dB) 至 100 kHz (-30 dB)
标称输入功率	40 W
最大输入功率	120 W
灵敏度	86 dB/2.83 V/m
分频频率	8 kHz
尺寸 (宽×高×深)	340 × 105 × 132 mm
重量	2 kg

- 由于产品改进, 若有规格变更恕不另行通知。
- 请小心不要超过上述注明的输入功率值。

爱护扬声器

擦拭本装置时, 请勿使用化学溶剂 (例如酒精或稀释剂等): 可能损坏涂层。请使用清洁的干布。对于难以清除的污点, 用水蘸湿软布, 拧干后进行擦拭。

(对于表面抛光的型号) 用金属、瓷器或其他硬物撞击设备的表面会导致涂层裂开或剥落。请小心使用。

